



Study on the implementation of the Internet of Things in the sustainable agricultural revolution from upstream to downstream

I Gede Suputra Widharma^{1*}, Ketut Sumadi², A. A. Made Dewi Anggreni³

¹Politeknik Negeri Bali, Badung Bali, Indonesia

²Universitas Hindu Negeri I Gusti Bagus Sugriwa, Denpasar Bali, Indonesia

³Universitas Udayana, Denpasar Bali, Indonesia

*Corresponding author

Email address: suputra@pnb.ac.id

DOI: <https://doi.org/10.61126/dtcs.v2i2.48>

ARTICLE INFO

Keywords:

sustainable
agriculture

Internet of Things
digital
communication

upstream to
downstream
implementation

smart regenerative
agriculture

ABSTRACT

This study employs a review-based methodology to explore the utilization of Internet of Things (IoT) technology within the agricultural industrial revolution, encompassing processes from upstream to downstream. IoT technology plays a pivotal role in accelerating the adoption of regenerative agriculture principles by enabling the integration of sensors, communication devices, and digital platforms into a unified system. This system facilitates the monitoring and optimization of sustainable agricultural practices, covering stages from planting to the distribution of agricultural products. The bidirectional digital communication established between human-to-system and system-to-human interactions ensures seamless information exchange. The research introduces a conceptual framework for smart regenerative agriculture, comprising smart farming (upstream), smart harvesting and packing, and smart marketing (downstream). By leveraging IoT technology, this framework aims to create an agricultural system that is not only more efficient and environmentally sustainable but also capable of addressing the challenges of national food security. Furthermore, the study examines various case studies of IoT implementation in other countries, providing valuable insights and benchmarks for its potential application in Indonesia.

Citation suggestion:

Widharma, I.G. S., Sumadi, K., & Anggreni, A. A. M. D. (2024). Study on the implementation of the Internet of Things in the sustainable agricultural revolution from upstream to downstream. *Digital Theory, Culture & Society*, 2(2), 113–120. <https://doi.org/10.61126/dtcs.v2i2.48>

Introduction

Regenerative agriculture is gaining increasing attention around the world as an approach capable of addressing the environmental and economic challenges facing the modern agricultural sector. This model not only emphasizes the importance of increasing productivity, but also focuses on restoring soil quality, reducing carbon emissions, and increasing biodiversity. As part of the global solution to the climate crisis, regenerative agriculture is a key element in sustainable food policies initiated by various countries, including Indonesia. Today, technology plays a strategic role in accelerating the implementation of regenerative agriculture principles. One technology that has received special attention is the Internet of Things (IoT). IoT provides an opportunity to integrate sensors, communication devices, and digital platforms to monitor and optimize agricultural processes from upstream to downstream, from planting to distribution of agricultural products. In research conducted by Sharma et al. (2020), IoT is proven to be able to increase efficiency up to 30% water use in dryland agriculture through real-time soil moisture monitoring. In addition, research by Reddy et al. (2021) found that IoT-based systems can reduce excess pesticide use by 25%, while increasing organic crop yields.

In line with this digital transformation, the Indonesian government under the leadership of the new president has also launched a technology-based national program for the sustainable agriculture sector. This policy seeks to reduce dependence on conventional agricultural practices that tend to damage ecosystems. The National Sustainable Agriculture Transformation Program, initiated by the government, supports the use of IoT technology as an integral part of modernizing the agricultural supply chain. The program is focused on strengthening

smart farming aspects that include soil monitoring, smart irrigation, and logistics optimization through real-time data.

However, there are still many challenges in implementing IoT in regenerative agriculture in Indonesia, especially related to the limited digital infrastructure in rural areas. According to research conducted by Hartono et al. (2022), there is still a significant digital divide between urban and rural areas, which impacts the slow adoption of IoT technology in agriculture. In addition, local farmers' awareness of the long-term benefits of IoT-based regenerative agriculture is still limited. Therefore, this research aims to examine how the application of IoT in regenerative agriculture from upstream to downstream can be effectively integrated in the Indonesian context, with a focus on the alignment of the new president's policy. By utilizing IoT technology, it is expected that a more efficient, environmentally friendly agricultural system will be created, and able to answer the challenges of national food security. This research will also analyze various case studies of IoT implementation in other countries as a reference for implementation in Indonesia.

Sustainable agriculture faces various challenges from upstream to downstream, including production efficiency, resource management, and food security. Internet of Things (IoT) technology has been recognized for its potential in supporting regenerative agriculture, but its implementation is still limited in some sectors. A key question is how IoT applications can be optimally integrated into agricultural processes to create an efficient and environmentally friendly supply chain from upstream to downstream. This research aims to examine the application of IoT technology in the entire agricultural cycle, from the production (upstream) to the distribution (downstream) stage.

Method

In this research, several methods are used, namely the qualitative and quantitative approach method in the form of data collection from field studies in several agricultural areas that have or will implement IoT, survey and interview methods conducted to farmers, IoT experts, and agricultural sector industries to understand the benefits, challenges, and expectations of IoT implementation, case study methods of areas that have implemented IoT in agriculture from upstream to downstream, and literature review methods from articles, journals, and reports related to IoT implementation in the agricultural sector. With this approach, the research is expected to be able to provide applicable recommendations to support the sustainable agricultural revolution based on IoT technology.

This research uses a mixed method approach to gain in-depth understanding. The qualitative method aims to explore the experience and implementation of IoT technology from a practitioner's perspective, while the quantitative method focuses on measuring the impact of IoT on agricultural efficiency and sustainability.

Qualitative

Case studies from various locations that have implemented IoT in agriculture (both upstream and downstream stages). In-depth interview techniques with farmers, farm managers, and distributors can be used to understand their experiences.

Quantitative

Conduct surveys with structured questionnaires to collect data on productivity improvements, resource efficiency, and sustainability resulting from IoT implementation.

Field experiments with live testing of IoT deployment on specific farming cycles were also conducted. This helps to directly verify the efficiency of IoT technology from production to distribution.

Interviews and Observations

Data collection: from interviews with stakeholders at different stages of the agricultural cycle.

Direct Observation: Observing the application of IoT technologies on farms, collecting data related to sensor utilization, big data usage, or other technologies in the distribution chain.

Literature Study

Industry Reports: Data on the application of IoT in agriculture from industry and government reports.

IoT Data (Sensors, Cameras, and IoT Devices): Data collected from IoT devices (e.g., water pH value sensor, rice field irrigation water temperature sensor, soil moisture sensor, weather data, good and failed product sorting data, product quality measurement in distribution).

Productivity and Efficiency Data: Retrieve productivity data from agricultural systems using IoT, such as changes in crop yields, water usage, energy, and distribution logistics efficiency.

Results and Discussion

Internet of Things design

The Internet of Things (IoT) is a communication medium for monitoring and control by utilizing the internet network. IoT provides opportunities to integrate sensors, communication devices, and digital platforms.

Figure 1. Internet of Things concept

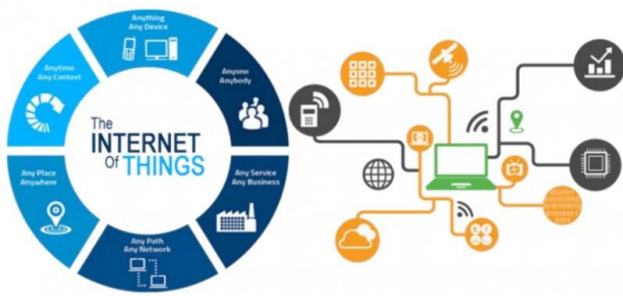

The internet and computing capabilities can encompass a wide array of objects, devices, sensors and everyday items.

The ESP32 microcontroller has WiFi and Bluetooth integration in it, making it easier to learn in the development of Internet of Things (IoT) systems that require wireless connections. In addition, this module can be applied in various fields such as system control, monitoring, and other uses. One significant feature of the ESP32 is its ability to switch to deep sleep mode to save power consumption, where the module can be disabled when not in use. The ESP32 microcontroller supports Bluetooth technology with dual-mode capability and efficient power usage. This provides more flexibility in various implementations.

The working principle of ESP32 that has been integrated into the microcontroller system (communicator) sends messages (information) to farmers or other stakeholders (communicants) through the

Figure 2. ESP32 microcontroller as the center of IoT

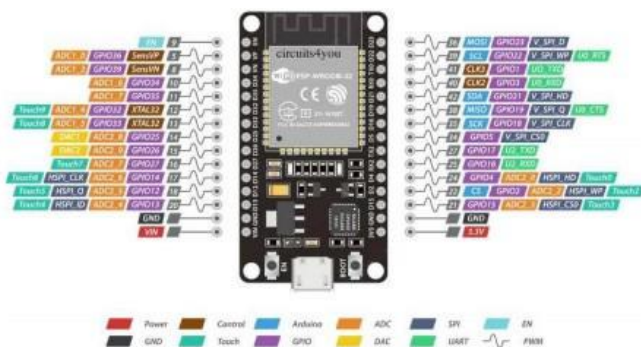
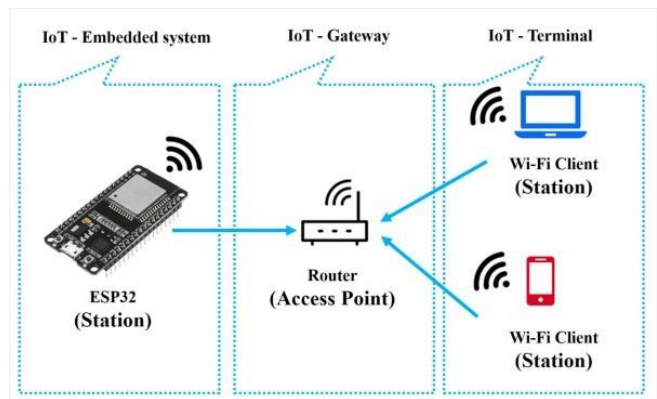

Figure 3. Digital communication in IoT



channel, namely the IoT gateway (router as an access point) and IoT terminal either portable (android/smartphone) or personal computer (PC).

Sensors and transducers

In supporting the implementation of IoT in sustainable agriculture from upstream to downstream, such as starting from the seed planting period which includes irrigation, seeding, and fertilization, it requires the support of components called sensors and transducers. The sensors commonly used in smart farming include pH value sensors, temperature sensors, and soil moisture sensors. Likewise, the harvest and post-harvest process requires a smart harvesting system that requires product sorting sensors such as product color sensors to the packing process with a smart packing system. While

Figure 4. Sensor design of pH value on IoT

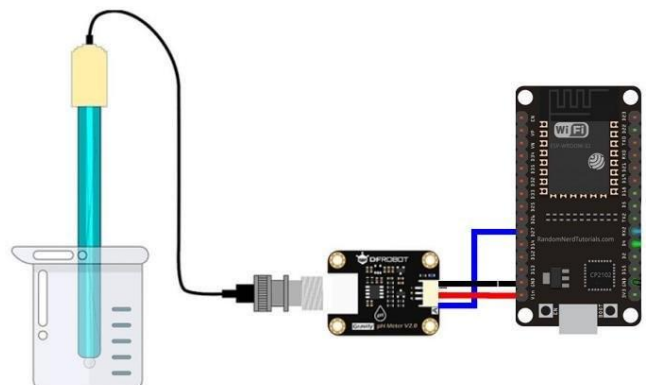

Figure 5. Design of water temperature sensor on IoT



downstream, smart marketing is needed with the main part being digital marketing utilizing internet media in the form of social media.

The upstream part starts from planting seeds in the smart farming system. The pH value sensor is used to monitor the pH value of the water used in the irrigation process (watering) on the farm. In water pH level is one of the parameters that can be used to determine water quality. So, it is very important to keep the pH level in accordance with the needs used. pH or Puissance de Hydrogen is the degree of acidity in determining the acidity or basicity of a solution. There are several ways or methods to measure the acidity of a solution, including by using a pH sensor that can be done automatically by connecting it to a microcontroller.

Temperature is one of the measurement parameters that is often used in the data acquisition process. One way to measure temperature parameters is by using a temperature sensor. A temperature sensor is a sensor that converts temperature quantities into electrical voltage. Many sensors can be used to measure temperature parameters such as the DS18B20 temperature sensor. This sensor has 3 foot pins, namely Vs, ground, and input/output data. The DS18B20

Figure 6. Design of temperature and humidity sensors on IoT

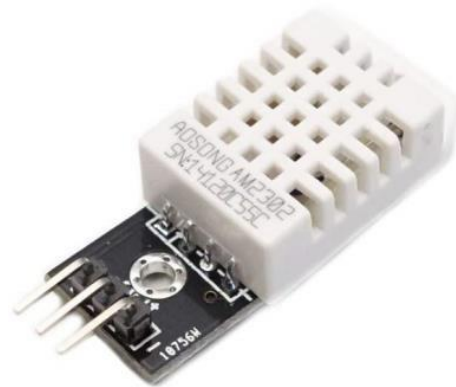

sensor is also waterproof so it can be used to measure water temperature.

The DHT22 or AM2302 sensor is a type of sensor that can detect and measure temperature and humidity levels in an environment or space with an output in the form of a digital signal, where conversion and calculation are carried out by an 8-bit integrated microcontroller. The wide temperature and humidity measurement range makes the DHT22 sensor a mainstay in environmental measurement applications. The DHT22 also has the ability to transmit its output signal via cable up to a distance of 20 meters.

Here is Capacitive Soil Moisture which is a different type of sensor from most resistive sensors on the market. This sensor uses capacitive sensing technology to detect soil moisture. The advantage is that resistive sensors that are easily corroded can be avoided so that their working life can be extended. The sensor is equipped with a built-in voltage regulator chip that supports a 3.3 volt working environment, so it can work on a 3.3V Arduino control board. In fact, miniature PCs such as Raspberry Pi only need an external ADC conversion module for this sensor to work.

Figure 7. Design of soil moisture sensor on IoT



Smart regenerative agriculture

Smart regenerative agriculture is a system that consists of several parts such as smart farming, smart harvesting, smart packing, and smart marketing. The smart farming studied is a type of sustainable agriculture starting from the planting period both monitoring and controlling the condition of agricultural land by utilizing sensors. Smart harvesting is the control of the harvest period to post-harvest to match the expected results. Smart packing is a system of sorting and selecting products according to their category until packing. Smart marketing includes the promotion process to the distribution of products to consumers.

The result of this study is the concept of smart regenerative agriculture, which is a sustainable agricultural system from upstream with smart farming to downstream with smart marketing that utilizes the internet (Internet of Things).

The application of the Internet of Things (IoT) in the agricultural sector has a major impact on operational efficiency, resource management, and environmental sustainability. An analysis of its impact shows significant benefits associated with increasing productivity, reducing waste, and maintaining a balanced agricultural ecosystem. IoT plays an important role in helping manage natural resources such as water, fertilizer, and energy. IoT sensors

Figure 8. Smart regenerative agriculture concept

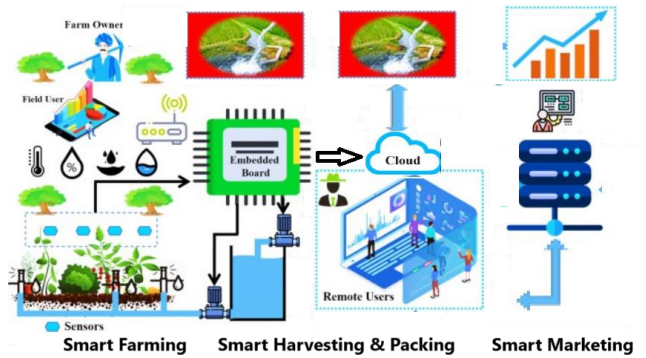

provide real-time data that enables more efficient use of resources. The application of IoT in the agricultural sector not only improves operational efficiency, but also has a positive impact on resource management and environmental sustainability.

Implementing this concept requires a thorough analysis that includes qualitative analysis, quantitative analysis, and evaluation of measurement and calculation results. Identifying key themes from interviews and observations. These could be implementation challenges, perceived benefits, and innovations driven by IoT technologies. Interview and observation notes to find common patterns in the use of IoT at different stages of the agricultural cycle.

Using descriptive statistics to describe the distribution of data related to productivity, resource efficiency, and improved product quality resulting from IoT implementation. Correlations can be measured to understand the impact of IoT on sustainability variables. By collecting IoT sensor data over a period of time, time series analysis can be used to look at changes in productivity, water usage, or energy over time. Assess the cost of implementing IoT technology compared to the benefits it brings, both in terms of productivity and environmental sustainability.

Table 1. Probability types of sensors and actuators of the concept

System	Parts	Sensor/Actuator	Description
Smart farming	Seeding	pH	Water pH value
		Temperature	Water temperature
	Irrigation	Flow	Flow velocity
Smart Harvesting	Pre-harvest	Ultrasonic	Water depth
		Movement	Bird movement
	Post-harvest	Buzzer	Bird repellent
Smart packing	Sorting	Smoke	combustion
		Limit switch	Movement limit
	Packing	Color	Color grading
Smart Marketing	Distribution	Limit switch	Container boundary
		Counter	Counting containers
	Promotion	Counter	Counting car
		Social media	Number of views
		Youtube	Number of views

Source: field work data

Conclusion

This research produces a smart regenerative agriculture concept consisting of smart farming (upstream), smart harvesting and packing, and smart marketing (downstream). By utilizing IoT technology, an agricultural system that is more efficient, environmentally friendly, and able to answer the challenges of national food security will be created. IoT provides an opportunity to integrate sensors, communication devices, and digital platforms in a system to monitor and optimize sustainable agricultural processes. The advantage of IoT integration in sustainable agriculture is the incorporation of IoT technology from upstream to downstream in one system. Business process optimization with this IoT technology integration enables superior operational efficiency. The role of data analysis in successful IoT integration in sustainable agriculture is important for making the right strategic decisions. This research also analyzes various case studies of IoT implementation in other countries as a reference for implementation in Indonesia.

Declaration of Ownership

This article is our original work.

Conflict of Interest

There is no conflict of interest to declare in this article.

Ethical Clearance

This study was approved by the institution.

References

- Bello, O. M., & Zeadally, S. (2019). Toward efficient smartification of the Internet of Things (IoT) services. *Future Generation Computer Systems*, 92, 663–673. <https://doi.org/10.1016/j.future.2017.09.083>
- Jayaraman, P.P., et al. (2016). Internet of Things platform for smart farming: Experiences and lessons learnt. *Sensors*, 16(11), 1884. <https://doi.org/10.3390/s16111884>

- Kamilaris, A., et al. (2016). A review on the practice of big data analysis in agriculture. *Computers and Electronics in Agriculture*, 143, 23–37. <https://doi.org/10.1016/j.compag.2017.09.037>
- Liakos, K.G., et al. (2018). Machine learning in agriculture: A review. *Sensors*, 18(8), 2674. <https://doi.org/10.3390/s18082674>
- Mekala, M. S., & Viswanathan, P. (2017). A survey: Smart agriculture IoT with cloud computing. *International conference on Microelectronic Devices, Circuits and Systems (ICMDCS)*, 1–7. <https://doi.org/10.1109/ICMDCS.2017.8211551>
- Sharma, C., Pathak, P., Kumar, A. et al. (2024). Sustainable regenerative agriculture allied with digital agri-technologies and future perspectives for transforming Indian agriculture. *Environ Dev Sustain*, 26(11), 78–98. <https://doi.org/10.1007/s10668-024-05231-y>
- Wolfert, S., et al. (2017). Big data in smart farming: A review. *Agricultural Systems*, 153, 69–80. <https://doi.org/10.1016/j.agsy.2017.01.023>